

## Elevation & Floor Space

*For Standard Model RMC, DDC, and ADC Cleated Belt Conveyors*

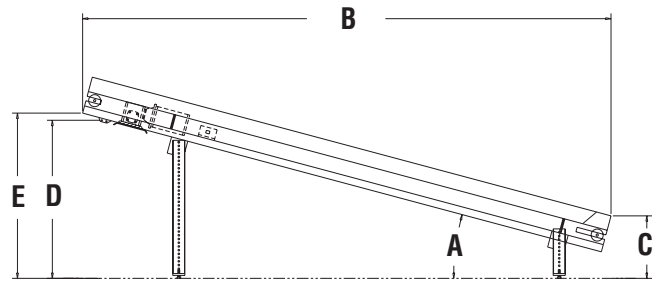

Con- veyor Length	ANGLE OF INCLINE (Dimensions In Inches)																							
	20°				25°				30°				35°				40°				45°			
	"B"	"C"	"D"	"E"	"B"	"C"	"D"	"E"	"B"	"C"	"D"	"E"	"B"	"C"	"D"	"E"	"B"	"C"	"D"	"E"	"B"	"C"	"D"	"E"
3'	38	10	11	12	37	10	14	15	37	10	16	18	36	9	19	21	35	9	21	23	33	8	23	25
4'	49	10	15	16	48	10	19	20	47	10	22	24	46	9	26	28	44	9	29	31	41	8	31	34
5'	60	10	19	21	59	10	24	25	57	10	28	30	55	9	32	34	53	9	36	39	50	8	40	42
6'	72	10	23	25	70	10	29	30	68	10	34	36	65	9	39	41	62	9	44	46	58	8	48	51
7'	83	10	28	29	81	10	34	35	78	10	40	42	75	9	46	48	71	9	52	54	67	8	57	59
8'	94	10	32	33	92	10	39	41	89	10	46	48	85	9	53	55	80	9	59	62	75	8	65	68
9'	105	10	36	37	103	10	44	46	99	10	52	54	95	9	60	62	90	9	67	69	84	8	74	76
10'	117	10	40	41	113	10	49	51	109	10	58	60	105	9	67	69	99	9	75	77	92	8	82	85
11'	128	10	44	45	124	10	54	56	120	10	64	66	114	9	74	76	108	9	83	85	101	8	91	93
12'	139	10	48	49	135	10	59	61	130	10	70	72	124	9	81	83	117	9	90	93	109	8	99	102
13'	151	10	52	53	146	10	64	66	141	10	76	78	134	9	87	89	126	9	98	100	118	8	108	110
14'	162	10	56	57	157	10	70	71	151	10	82	84	144	9	94	96	136	9	106	108	126	8	116	119
15'	173	10	60	62	168	10	75	76	161	10	88	90	154	9	101	103	145	9	113	116	135	8	125	127
16'	184	10	64	66	179	10	80	81	172	10	94	96	164	9	108	110	154	9	121	123	143	8	133	136
17'	196	10	69	70	190	10	85	86	182	10	100	102	173	9	115	117	163	9	129	131	152	8	142	144
18'	207	10	73	74	200	10	90	91	193	10	106	108	183	9	122	124	172	9	137	139	160	8	150	153
19'	218	10	77	78	211	10	95	96	203	10	112	114	193	9	129	131	182	9	144	147	169	8	159	161
20'	229	10	81	82	222	10	100	101	213	10	118	120	203	9	136	138	191	9	152	154	177	8	167	170
21'	241	10	85	86	233	10	105	107	224	10	124	126	213	9	143	145	200	9	160	162	186	8	176	178
22'	252	10	89	90	244	10	110	112	234	10	130	132	222	9	149	151	209	9	167	170	194	8	184	187
23'	263	10	93	94	255	10	115	117	245	10	136	138	232	9	156	158	218	9	175	177	203	8	193	195
24'	275	10	97	99	266	10	120	122	255	10	142	144	242	9	163	165	228	9	183	185	211	8	201	204
25'	286	10	101	103	277	10	125	127	265	10	148	150	252	9	170	172	237	9	191	193	220	8	210	212
26'	297	10	106	107	287	10	130	132	276	10	154	156	262	9	177	179	246	9	198	201	228	8	218	221
27'	308	10	110	111	298	10	135	137	286	10	160	162	272	9	184	186	255	9	206	208	237	8	227	229
28'	320	10	114	115	309	10	141	142	296	10	166	168	281	9	191	193	264	9	214	216	245	8	235	238
29'	331	10	118	119	320	10	146	147	307	10	172	174	291	9	198	200	274	9	221	224	254	8	244	246
30'	342	10	122	123	331	10	151	152	317	10	178	180	301	9	204	206	283	9	229	231	262	8	252	255

## Elevation & Floor Space Formulas for All Incline Conveyors

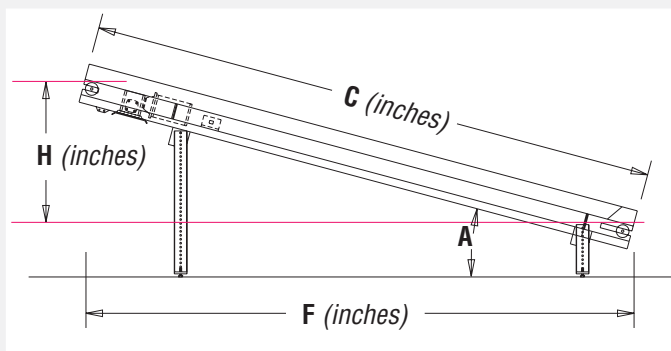

(All Dimensions in Inches)				
Known:	Want to Find:			
	A	H	F	C
H, F	$(H/F) \text{ ATAN}$			$\text{SQRT}(H^2 + F^2)$
H, C	$(H/C) \text{ ASIN}$		$\text{SQRT}(C^2 - H^2)$	
A, H				$H / \sin A$
A, F		$F (\tan A)$		$F / \cos A$
A, C		$C (\sin A)$	$C (\cos A)$	